

Areamaster™ Generation 2 LED Zone 1 Luminaire

Floodlight for Hazardous Locations

ATEX/IECEX:
 Zone 1, 2, 21 and 22
 Ex eb mb op is IIC
 II 2 GD
 IP64, 66, 67

ATEX/IECEX:
 IK08

Applications

- For use in locations where:
 - Hazardous areas designated as: Zone 1, 2, 21 and 22
 - A high degree of corrosion resistance is required
 - Protection against gas, dust, water and moisture is necessary
- Typical applications include:
 - A wide range of harsh and hazardous areas where flammable gases and vapors are present, for example:
 - Oil and Gas Refineries
 - Petrochemical Plants
 - Foundries
 - Drilling Rigs
 - Pulp and Paper Mills
 - Food and Beverage Processing Facilities
 - Loading Docks
 - Power Plants
 - Water and Wastewater Treatment Facilities
 - Other areas where corrosive, wet, dirty and tough environments are a problem
 - IP64, 66, 67; marine and wet locations
 - Extreme hot/cold temperature environments: -40°C to +65°C (-40°F to +149°F)



Features

- Three lumen outputs provide up to 18,500 lumens.

Nominal Lumens ①	Wattage (W)	Efficacy (lpw)	HID Equivalent	Model Number
9,000	65	139	175W-250W	AMLZL6
14,000	105	133	250W-400W	AMLZL7
18,500	144	129	400W-750W	AMLZL8

① Nominal lumen value for 5000K CCT. Detailed lumen information provided in tables.

- Separate field wiring compartment with screw terminal block for easy and secure connection (can accept UL/CSA 26-10 AWG, 4 to 6 mm²)
- Two 3/4" NPT entries provided. Metric M20 plugs available.
- Yoke bracket is designed to accommodate traditional Areamaster brackets and slipfitters for easy retrofit.
- Choice of color temperature (CCT): 5000K cool white, 4000K neutral white or 3000K warm white
- Rugged and compact housing with superior thermal design translates to long luminaire life
- Heavy duty, high temperature silicone rubber gaskets
- Thermal shock and impact resistant clear or frosted glass lens
- Standard 6Kv surge protection
- Captive fasteners secure on piece lens
- Field replaceable LED driver and lens cover
- Photobiological safety rating: Risk Group Zero (RG0) with frosted glass; Risk Group One (RG1) with clear glass

Options

- Improved safety cable design with multiple retention points, purchase separately.
- Guard and visor available, purchase separately
- Slip-fitters and mounting brackets available for easy pole or wall mounting

Standard Materials

- Housing and lens door: copperfree aluminum (4/10 of 1% maximum)
- Gaskets: silicone rubber
- Yoke: zinc plated HR steel
- Bolts: stainless steel
- Close up plugs: (1) aluminum provided
- Guard and safety cable: stainless steel
- Visor: aluminum

Standard Finishes

- Housing, lens cover, visor and yoke mount: architectural bronze polyester

ATEX/IECEX Certifications and Compliances

- Certification Type: Areamaster Gen 2
 - Gas: Zone 1 and 2
 - Conforming to ATEX 2014/34/EU: II 2G
 - Type of Protection: Ex eb mb op is IIC Gb
 - Temperature Class: T6 to T4
 - Dust: Zones 21 and 22
 - Conforming to ATEX 2014/34/EU: II 2D
 - Type of Protection: Ex op is tb IIIC Db
 - Surface Temperature: +85°C to +100°C (-185°F to +212°F)
- Ambient Temperature: -40 °C to +65 °C (-40 °F to +149 °F)
- ATEX Certificate: ITS18ATEX303521
- IECEX Certificate: IECEx ITS 18.0031
- Index of Protection according to EN/IEC 60529: IP64, 66, 67
- Impact Resistance (shock): IK08
- Photobiological Safety, IEC 62778 and IEC 62471: RG0 with frosted glass, RG1 with clear glass

Areamaster™ Generation 2 LED Zone 1 Luminaire

Floodlight for Hazardous Locations

ATEX/IECEX:
 Zone 1, 2, 21 and 22
 Ex eb mb op is IIC
 II 2 GD
 IP64, 66, 67

ATEX/IECEX:
 IK08

Order using catalog numbering guides below or select catalog number from tables on following pages.

AMLZ	L7	C	G	6	BU	M
Series: AMLZ: Areamaster Generation 2 LED Zone 1	Lumen Level ①: L6 – 9K L7 – 14K L8 – 18.5K	Color Temp CCT: C - 5000K (Cool White) N - 4000K (Neutral) W - 3000K (Warm White)	Diffusion: G - Clear Glass F - Frosted Glass ②	Beam Spread: 6 - 7x7 7 - 7x6	Voltage: BU - 120-277 Vac 50/60 Hz, 170-300 Vdc	Options: M - M20 Metric

Lumen Output Tables:

Lumen Output for Clear Glass Lens			
Luminaire Beam Spread	AMLZL6	AMLZL7	AMLZL8
NEMA 7x6, 5000K CCT, CRI 70	9196	14343	18558
NEMA 7x6, 3000K CCT, CRI 80	8312	12965	16775
NEMA 7x7, 5000K CCT, CRI 70	9027	14029	18104
NEMA 7x7, 3000K CCT, CRI 70	8159	12681	16364

Lumen Output for Frosted Glass Lens			
Luminaire Beam Spread	AMLZL6	AMLZL7	AMLZL8
NEMA 7x7, 5000K CCT, CRI 70	7454	11563	14993
NEMA 7x7, 3000K CCT, CRI 80	6737	10451	13553

① All lumen values are typical (tolerance +/-10%).

② Frosted Glass is only available with NEMA 7x7 light pattern.

Areamaster™ Generation 2 LED Zone 1 Luminaire

Floodlight for Hazardous Locations

ATEX/IECEX:
 Zone 1, 2, 21 and 22
 Ex eb mb op is IIC
 II 2 GD
 IP64, 66, 67

ATEX/IECEX:
 IK08

Electrical Ratings

Voltage Suffix	Voltage (V)	Input Power (Watts)	Input Current (Amps)	Power Factor (PF)	Total Harmonic Distortion (THD)	Model Number	
BU	120 Vac	65	0.6	0.99	< 20%	AMLZL6	
	277 Vac	63	0.3	0.93			
	170 Vdc	63	0.5	N/A	N/A		
	300 Vdc	63	0.3				
	120 Vac	105	0.9	0.99	< 20%		AMLZL7
	277 Vac	103	0.4	0.94			
	170 Vdc	103	0.7	N/A	N/A		
	300 Vdc	103	0.4				
	120 Vac	140	1.2	0.99	< 20%	AMLZL8	
	277 Vac	135	0.5	0.93			
	170 Vdc	138	0.8	N/A	N/A		
	300 Vdc	136	0.5				

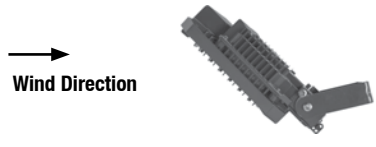
Luminaire Category	Image	Frontal Projected Area (FPA) m ² (ft ²)	Drag Coefficient (DC)	Effective Projected Area (EPA) = FPA*DC m ² (ft ²)
90° to Ground-Worst Case Mounting		0.5 (1.52)	1.20	0.6 (1.82)
45° to Ground-Standard Mounting		0.3 (1.07)	1.20	0.4 (1.28)

Areamaster™ Generation 2 LED Zone 1 Luminaire

Floodlight for Hazardous Locations

ATEX/IECEX:
 Zone 1, 2, 21 and 22
 Ex eb mb op is IIC
 II 2 GD
 IP64, 66, 67

ATEX/IECEX:
 IK08

ATEX/IECEX Temperature Codes

Gas			Dust			Model Number
T Rating			Surface T°			
Ta= +40 °C (+104 °F)	Ta= +55 °C (+131 °F)	Ta= +65 °C (+149 °F)	Ta= +40 °C (+104 °F)	Ta= +55 °C (+131 °F)	Ta= +65 °C (+149 °F)	
T6	T5	T5	85°C (185°F)	85°C (185°F)	85°C (185°C)	AMLZL6
T4	T4	T4	85°C (185°F)	100°C (212°F)	100°C (212°F)	AMLZL7
T4	T4	T4	85°C (185°F)	100°C (212°F)	100°C (212°F)	AMLZL8

“T” Numbers Represent the Maximum Internal Temperature or Maximum Surface Temperature

“T” #	T1	T2	ATEX/IECEX T3	T4	T5	T6
Temp. Range °C (°F)	301-450 (547-842)	201-300 (394-572)	136-200 (277-392)	101-135 (214-275)	86-100 (187-212)	85 (185)



APPLETON™

LED/FLOODLIGHTS: NEC/CEC, ATEX/IECEX ENCLOSED AND GASKETED

Areamaster™ Generation 2 LED Zone 1 Luminaire Floodlight for Hazardous Locations

ATEX/IECEX:
Zone 1, 2, 21 and 22
Ex eb mb op is IIC
II 2 GD
IP64, 66, 67

ATEX/IECEX:
IK08

	Color Temperature (CCT)	Lumen Output	Wattage	Efficacy (lm/W)	Input Current (Amps)	Optical Pattern	Catalog Number
Frosted Glass — 120-277 Vac/170-300 Vdc							
	5000K	7454	65	114	0.41	7x7 (159°x157°)	AMLZL6CF6BUM
	3000K	6737		103			AMLZL6WF6BUM
	5000K	11563	105	110	0.68	7x7 (159°x156°)	AMLZL7CF6BUM
	3000K	10451		100			AMLZL7WF6BUM
	5000K	14993	144	104	0.93	7x7 (159°x156°)	AMLZL8CF6BUM
	3000K	13553		94			AMLZL8WF6BUM
Clear Glass — 120-277 Vac/170-300 Vdc							
	5000K	9027	65	138	0.41	7x7 (134°x144°)	AMLZL6CG6BUM
	5000K	9196		141		7x6 (139°x128°)	AMLZL6CG7BUM
	3000K	8159		125		7x7 (134°x144°)	AMLZL6WG6BUM
	3000K	8312		127		7x6 (139°x128°)	AMLZL6WG7BUM
	5000K	14029	105	134	0.68	7x7 (133°x145°)	AMLZL7CG6BUM
	5000K	14343		137		7x6 (138°x127°)	AMLZL7CG7BUM
	3000K	12681		121		7x7 (133°x145°)	AMLZL7WG6BUM
	3000K	12965		123		7x6 (138°x127°)	AMLZL7WG7BUM
	5000K	18104	144	126	0.93	7x7 (132°x145°)	AMLZL8CG6BUM
	5000K	18558		129		7x6 (138°x127°)	AMLZL8CG7BUM
	3000K	16364		114		7x7 (132°x145°)	AMLZL8WG6BUM
	3000K	16775		116		7x6 (138°x127°)	AMLZL8WG7BUM

APPLETON™

LED/FLOODLIGHTS: NEC/CEC, ATEX/IECEX ENCLOSED AND GASKETED

Areamaster™ Generation 2 LED Zone 1 Luminaire Floodlight for Hazardous Locations

ATEX/IECEX:
Zone 1, 2, 21 and 22
Ex eb mb op is IIC
II 2 GD
IP64, 66, 67

ATEX/IECEX:
IK08

Accessories and Replacement Parts

	Description	Catalog Number
Crossarm Mounting Bracket		
	Has 180° horizontal adjustment — degree marked. Facilitates mounting floodlight to crossarm or other flat surface, or to G-AM-8-WB. Includes floodlight yoke bolts. Malleable iron, zinc plated, chromate sealed, architectural bronze polyester finish.	G-AM-8-CA
Pipe or Wall Mount Bracket		
	Used with G-AM-8-CA. Clamps to 1" to 2-1/2" pipe, vertical or horizontal, or mounts on flat surfaces. Includes U-bolt and crossarm bracket bolts. Malleable iron, zinc plated, chromate sealed, with architectural bronze polyester finish.	G-AM-8-WB
		
Crossarm Mounting Bracket (G-AM-8-CA) used with Pipe or Wall Mount Bracket (G-AM-8-WB).		
Poletop Slip-Fitter		
	Slip-fits 1-1/2" or 2" pipe size poletop tenons. Includes floodlight yoke bolts, 3 locking bolts, and cord grip. Body is malleable iron-zinc plated, chromate sealed, with cast aluminum cap. Assembly has architectural bronze polyester finish.	G-SF20
	Slip-fits 1" or 1-1/2" pipe size poletop tenons. Includes floodlight yoke bolts, 3 locking bolts, and cord grip. Body is malleable iron-zinc plated, chromate sealed, with cast aluminum cap. Assembly has architectural bronze polyester finish.	AMLEDSF1
Poletop Slip-Fitter		
	Slip-fits 2" or 2-1/2" poletop tenons. Includes floodlight yoke bolts, 3 locking bolts, and cord grip. Malleable iron, zinc plated, chromate sealed, with architectural bronze polyester finish.	G-AM-8-SF

APPLETON™

LED/FLOODLIGHTS: NEC/CEC, ATEX/IECEX ENCLOSED AND GASKETED





Areamaster™ Generation 2 LED Zone 1 Luminaire

Floodlight for Hazardous Locations

ATEX/IECEX:
 Zone 1, 2, 21 and 22
 Ex eb mb op is IIC
 II 2 GD
 IP64, 66, 67

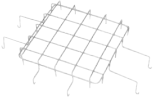
ATEX/IECEX:
 IK08

Accessories and Replacement Parts

	Description	Catalog Number
Wall Mount Bracket		
	Used with G-AM-8-SF and GSF-20 to provide a wall mounting option. Galvanized Steel.	GPSWB6GAL
Wire Guard		
	Stainless steel.	LGGUARD
Safety Cable		
	Stainless steel.	LEDSC
Visor		
	Steel with architectural bronze polyester finish. For Dark Sky Friendly design.	AMLGV
Portable Floodlight Base		
	Portable floodlight base for temporary lighting applications. To be used with wire guard. Malleable iron with architectural bronze polyester finish.	G-AM-PFB
Replacement Covers		
		AMLZCLEAR
		AMLZFROST

Areamaster™ Generation 2 LED Zone 1 Luminaire

Floodlight for Hazardous Locations

ATEX/IECEX:
 Zone 1, 2, 21 and 22
 Ex eb mb op is IIC
 II 2 GD
 IP64, 66, 67

ATEX/IECEX:
 IK08

Replacement Drivers

	Voltage	Driver Wattage	Constant Current Setting	Luminaire Models	CCT	Catalog Number
	BU	100	410ma	AMLZL6	5000K	APMZ100C090UD41
					4000K	
					3000K	
	BU	150	680ma	AMLZL7	5000K	APMZ150C135UD68
					4000K	
					3000K	
	BU	150	930ma	AMLZL8	5000K	APMZ150C135UD93
					4000K	
					3000K	

Areamaster Generation 2 Accessory Weights

Description	Weight in kg (lbs)
AMLZL6, AMLZL7, AMLZL8 Luminaires	10.5 (23)
Yoke Bracket	1.41 (3.1)
Visor	0.2 (0.4)
Guard	0.2 (0.4)
Safety Cable	0.2 (0.4)
Crossarm Mounting Bracket G-AM-8-CA	1.4 (3.1)
Pipe or Wall Mount Bracket G-AM-8-WB	2.9 (6.4)
Poletop Slip-Fitter GSF20	1.4 (3.1)
Poletop Slip-Fitter AMLEDSF1	2.4 (5.3)
Poletop Slip-Fitter GAM8SF	—

APPLETON™

LED/FLOODLIGHTS: NEC/CEC, ATEX/IECEX ENCLOSED AND GASKETED

Areamaster™ Generation 2 LED Zone 1 Luminaire Floodlight for Hazardous Locations

ATEX/IECEX:
Zone 1, 2, 21 and 22
Ex eb mb op is IIC
II 2 GD
IP64, 66, 67

ATEX/IECEX:
IK08

Dimensions in Millimeters (Inches)

Floodlight

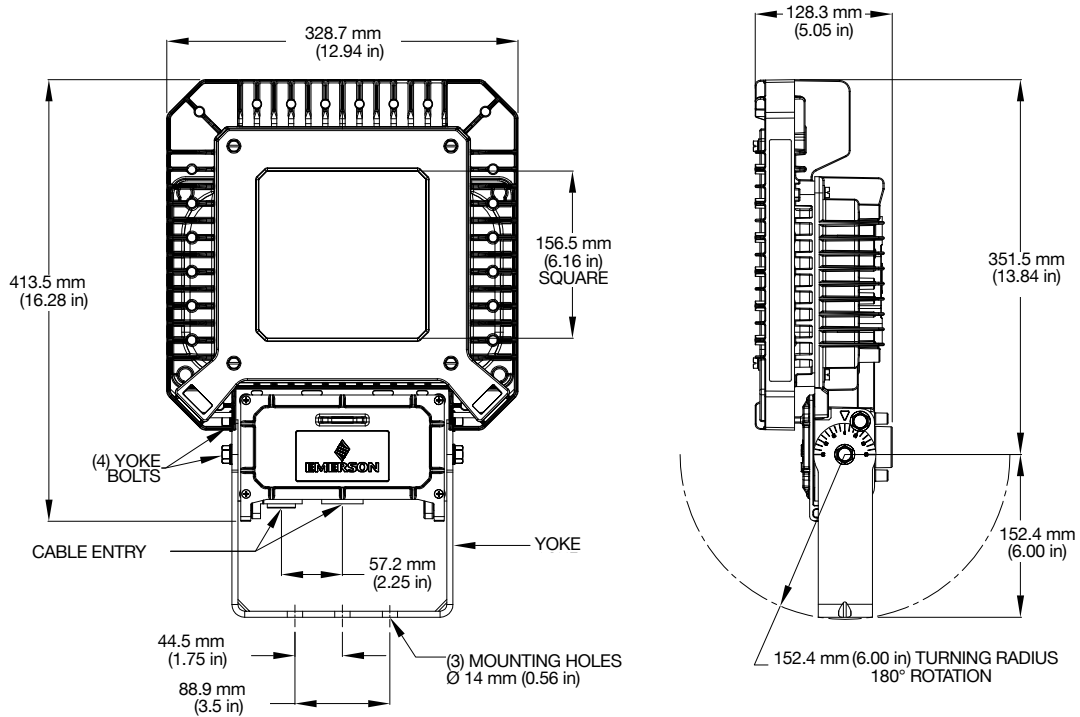

(4) 1/4-20 UNC-2B THREAD

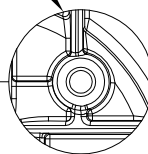
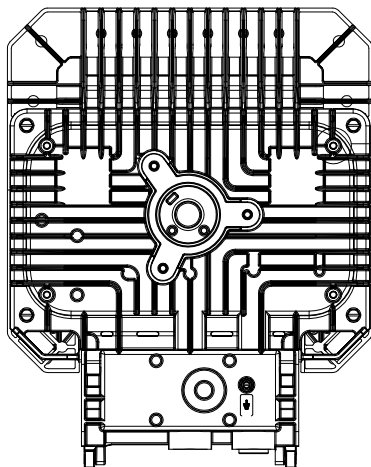

(2) HUBS FOR 3/4" NPT OR M20 METRIC

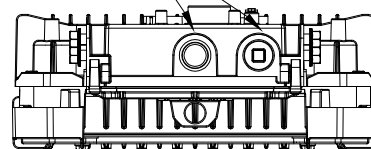

APPLETON™

LED/FLOODLIGHTS: NEC/CEC, ATEX/IECEX ENCLOSED AND GASKETED

Areamaster™ Generation 2 LED Zone 1 Luminaire

Floodlight for Hazardous Locations

ATEX/IECEX:
 Zone 1, 2, 21 and 22
 Ex eb mb op is IIC
 II 2 GD
 IP64, 66, 67

ATEX/IECEX:
 IK08

Photometric Data – DATA SHOWN IS ABSOLUTE

NEMA 7x7, Frosted Glass, 5000K CCT

REPORT NUMBER: AMLZL6CF6BUM

Luminaire Lumens 7,454

POLAR CANDELA DISTRIBUTION

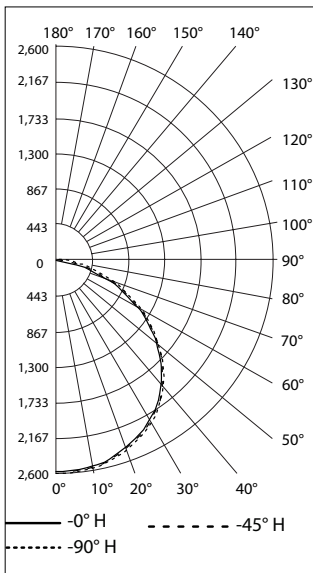

ISOFOOT CANDLE PLOT AT 45°

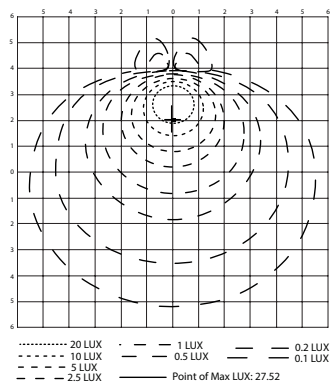

FLOOD SUMMARY

	Efficiency	Lumens	Horizontal Spread	Vertical Spread
Field (10%)	97.5%	7,280	159°	157°
Beam (50%)	75.5%	5,640	113°	114°
Total	100%	7,454		

Tilt Angle– 45 Degree LLF–0.9

Mounting Height (ft)	Forward Throw Distance			
	0.5fc/5lx m (ft)	1fc/11lx m (ft)	2fc/22lx m (ft)	5fc/54lx m (ft)
6 (20)	12 (40)	9 (30)	6 (20)	0
9 (30)	13 (42)	9 (29)	2 (8)	0
12 (40)	12 (40)	5 (16)	0	0

Mounting Height (ft)	Side-to-Side Distance			
	0.5fc/5lx m (ft)	1fc/11lx m (ft)	2fc/22lx m (ft)	5fc/54lx m (ft)
6 (20)	18 (60)	13 (44)	9 (30)	0
9 (30)	18 (60)	11 (36)	0	0
12 (40)	18 (60)	7 (24)	0	0

NEMA 7x7, Clear Glass, 5000K

REPORT NUMBER: AMLZL6CG6BUM

Luminaire Lumens 9,027

POLAR CANDELA DISTRIBUTION

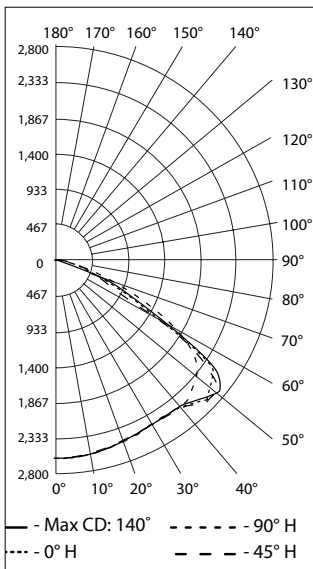

ISOFOOT CANDLE PLOT AT 45°

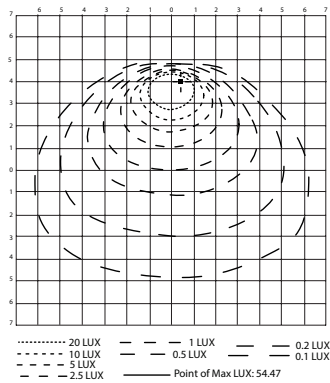

FLOOD SUMMARY

	Efficiency	Lumens	Horizontal Spread	Vertical Spread
Field (10%)	98.3%	8,897	134°	144°
Beam (50%)	90.1%	8,153	95°	120°
Total	100%	9,027		

Tilt Angle– 45 Degree LLF–0.9

Mounting Height (ft)	Forward Throw Distance			
	0.5fc/5lx m (ft)	1fc/11lx m (ft)	2fc/22lx m (ft)	5fc/54lx m (ft)
6 (20)	12 (40)	9 (30)	6 (20)	2 (5)
9 (30)	14 (45)	18 (60)	5 (15)	0
12 (40)	12 (40)	6 (20)	0	0

Mounting Height (ft)	Side-to-Side Distance			
	0.5fc/5lx m (ft)	1fc/11lx m (ft)	2fc/22lx m (ft)	5fc/54lx m (ft)
6 (20)	22 (72)	15 (50)	12 (40)	3 (10)
9 (30)	22 (72)	16 (54)	9 (30)	0
12 (40)	24 (80)	12 (40)	0	0

Areamaster™ Generation 2 LED Zone 1 Luminaire

Floodlight for Hazardous Locations

ATEX/IECEX:
 Zone 1, 2, 21 and 22
 Ex eb mb op is IIC
 II 2 GD
 IP64, 66, 67

ATEX/IECEX:
 IK08

Photometric Data – DATA SHOWN IS ABSOLUTE

NEMA 7x6, Clear Glass, 5000K CCT
 REPORT NUMBER: AMLZL6CG7BUM
 Luminaire Lumens 9,196

POLAR CANDELA DISTRIBUTION

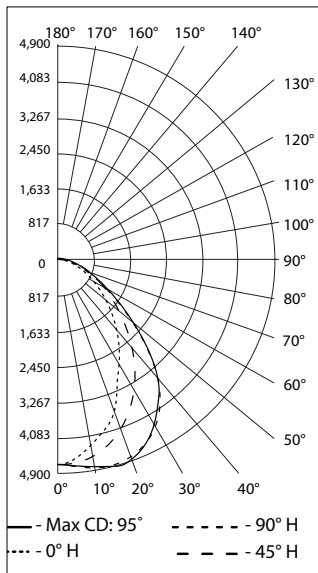

ISOFOOT CANDLE PLOT AT 45°

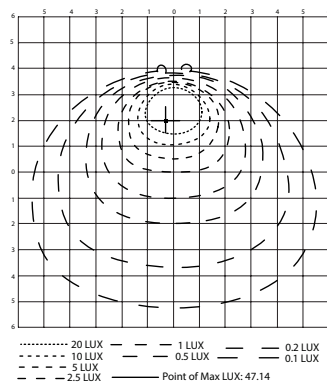

FLOOD SUMMARY

	Efficiency	Lumens	Horizontal Spread	Vertical Spread
Field (10%)	96%	8,843	139°	128°
Beam (50%)	65.1%	6,000	95°	69°
Total	100%	9,196		

Tilt Angle– 45 Degree LLF–0.9

Mounting Height (ft)	Forward Throw Distance			
	0.5fc/5lx m (ft)	1fc/11lx m (ft)	2fc/22lx m (ft)	5fc/54lx m (ft)
6 (20)	13 (44)	10 (34)	9 (28)	4 (12)
9 (30)	16 (53)	13 (42)	8 (26)	0
12 (40)	16 (52)	12 (40)	0	0

Mounting Height (ft)	Side-to-Side Distance			
	0.5fc/5lx m (ft)	1fc/11lx m (ft)	2fc/22lx m (ft)	5fc/54lx m (ft)
6 (20)	21 (68)	16 (52)	12 (40)	4 (14)
9 (30)	22 (72)	17 (57)	9 (30)	0
12 (40)	24 (80)	15 (48)	0	0

NEMA 7x7, Frosted Glass, 5000K CCT
 REPORT NUMBER: AMLZL7CF6BUM
 Luminaire Lumens 11,563

POLAR CANDELA DISTRIBUTION

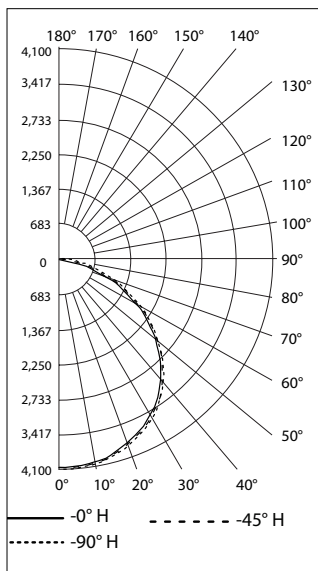

ISOFOOT CANDLE PLOT AT 45°

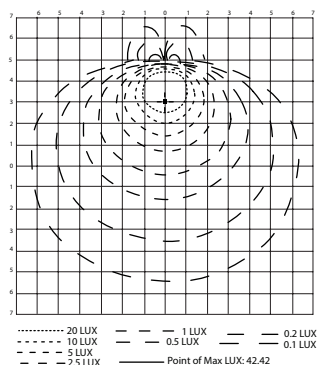

FLOOD SUMMARY

	Efficiency	Lumens	Horizontal Spread	Vertical Spread
Field (10%)	97.5%	11,295	159°	156°
Beam (50%)	75.3%	8,725	112°	114°
Total	100%	11,563		

Tilt Angle– 45 Degree LLF–0.9

Mounting Height (ft)	Forward Throw Distance			
	0.5fc/5lx m (ft)	1fc/11lx m (ft)	2fc/22lx m (ft)	5fc/54lx m (ft)
6 (20)	15 (48)	11 (36)	8 (26)	3 (10)
9 (30)	16 (51)	9 (30)	5 (15)	0
12 (40)	15 (50)	10 (32)	0	0

Mounting Height (ft)	Side-to-Side Distance			
	0.5fc/5lx m (ft)	1fc/11lx m (ft)	2fc/22lx m (ft)	5fc/54lx m (ft)
6 (20)	22 (72)	15 (50)	12 (40)	5 (16)
9 (30)	22 (72)	16 (54)	9 (30)	0
12 (40)	24 (80)	17 (56)	0	0

Areamaster™ Generation 2 LED Zone 1 Luminaire

Floodlight for Hazardous Locations

ATEX/IECEX:
 Zone 1, 2, 21 and 22
 Ex eb mb op is IIC
 II 2 GD
 IP64, 66, 67

ATEX/IECEX:
 IK08

Photometric Data – DATA SHOWN IS ABSOLUTE

NEMA 7x7, Clear Glass, 5000K

REPORT NUMBER: AMLZL7CG6BUM

Luminaire Lumens 14,029

POLAR CANDELA DISTRIBUTION

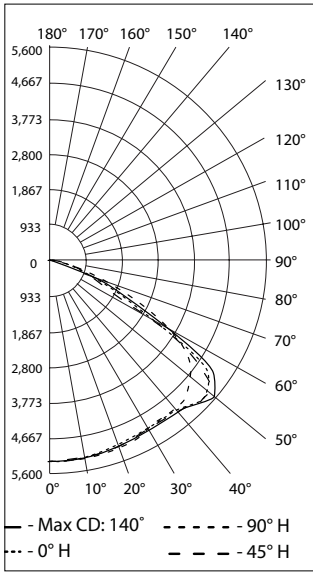

ISOFOOT CANDLE PLOT AT 45°

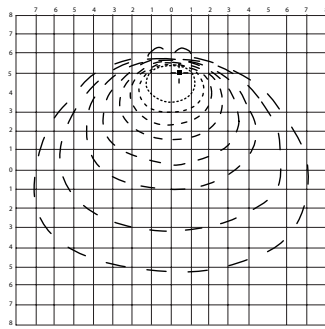

..... 20 LUX --- 1 LUX --- 0.2 LUX
 - - - 10 LUX - - - 0.5 LUX --- 0.1 LUX
 - - - 5 LUX - - - 2.5 LUX

FLOOD SUMMARY

	Efficiency	Lumens	Horizontal Spread	Vertical Spread
Field (10%)	98.4%	13,830	133°	145°
Beam (50%)	90.1%	12,669	94°	121°
Total	100%	14,029		

Tilt Angle– 45 Degree LLF–0.9

Mounting Height (ft)	Forward Throw Distance			
	0.5fc/5lx m (ft)	1fc/11lx m (ft)	2fc/22lx m (ft)	5fc/54lx m (ft)
6 (20)	14 (46)	11 (36)	8 (25)	4 (12)
9 (30)	16 (53)	11 (36)	7 (23)	0
12 (40)	16 (52)	10 (34)	2 (8)	0

Mounting Height (ft)	Side-to-Side Distance			
	0.5fc/5lx m (ft)	1fc/11lx m (ft)	2fc/22lx m (ft)	5fc/54lx m (ft)
6 (20)	24 (80)	18 (60)	13 (44)	9 (28)
9 (30)	27 (90)	20 (66)	15 (48)	0
12 (40)	28 (92)	21 (68)	0	0

NEMA 7x6, Clear Glass, 5000K CCT

REPORT NUMBER: AMLZL7CG7BUM

Luminaire Lumens 14,343

POLAR CANDELA DISTRIBUTION

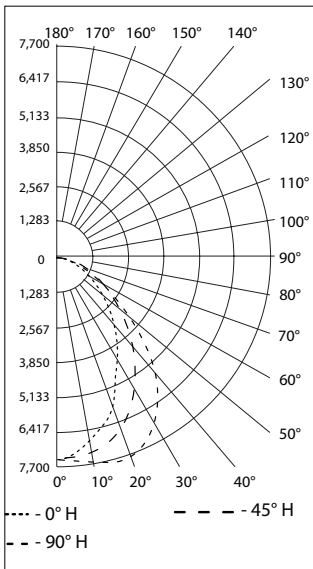

ISOFOOT CANDLE PLOT AT 45°

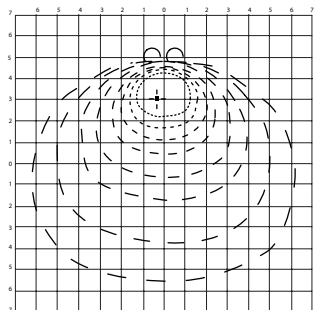

..... 20 LUX --- 1 LUX --- 0.2 LUX
 - - - 10 LUX - - - 0.5 LUX --- 0.1 LUX
 - - - 5 LUX - - - 2.5 LUX

FLOOD SUMMARY

	Efficiency	Lumens	Horizontal Spread	Vertical Spread
Field (10%)	96%	13,801	138°	127°
Beam (50%)	65.3%	9,390	94°	69°
Total	100%	14,343		

Tilt Angle– 45 Degree LLF–0.9

Mounting Height (ft)	Forward Throw Distance			
	0.5fc/5lx m (ft)	1fc/11lx m (ft)	2fc/22lx m (ft)	5fc/54lx m (ft)
6 (20)	16 (52)	13 (42)	9 (30)	7 (22)
9 (30)	18 (60)	14 (45)	10 (33)	0
12 (40)	20 (64)	15 (48)	6 (20)	0

Mounting Height (ft)	Side-to-Side Distance			
	0.5fc/5lx m (ft)	1fc/11lx m (ft)	2fc/22lx m (ft)	5fc/54lx m (ft)
6 (20)	23 (76)	18 (60)	13 (44)	9 (30)
9 (30)	27 (90)	20 (66)	15 (48)	0
12 (40)	29 (60)	22 (72)	9 (28)	0

Areamaster™ Generation 2 LED Zone 1 Luminaire

Floodlight for Hazardous Locations

ATEX/IECEX:
 Zone 1, 2, 21 and 22
 Ex eb mb op is IIC
 II 2 GD
 IP64, 66, 67

ATEX/IECEX:
 IK08

Photometric Data – DATA SHOWN IS ABSOLUTE

NEMA 7x7, Frosted Glass, 5000K CCT
 REPORT NUMBER: AMLZL8CF6BUM
 Luminaire Lumens 14,993

POLAR CANDELA DISTRIBUTION

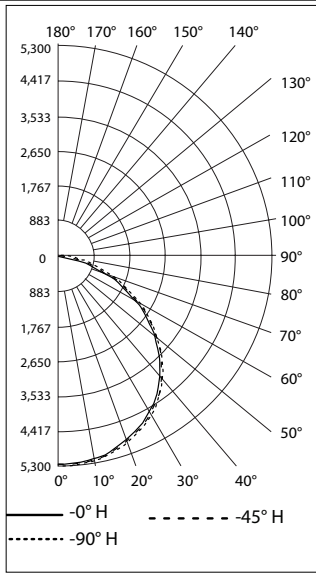

ISOFOOT CANDLE PLOT AT 45°

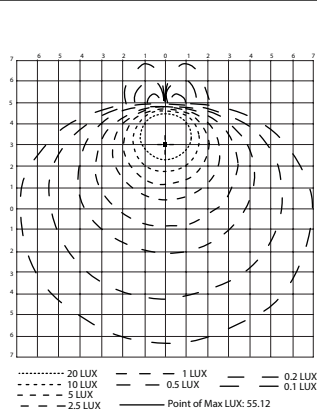

FLOOD SUMMARY

	Efficiency	Lumens	Horizontal Spread	Vertical Spread
Field (10%)	97.5%	14,648	159°	156°
Beam (50%)	75.4%	11,323	112°	114°
Total	100%	14,993		

Tilt Angle– 45 Degree LLF–0.9

Mounting Height (ft)	Forward Throw Distance			
	0.5fc/5lx m (ft)	1fc/11lx m (ft)	2fc/22lx m (ft)	5fc/54lx m (ft)
6 (20)	16 (52)	12 (40)	9 (30)	6 (20)
9 (30)	18 (59)	14 (54)	9 (30)	0
12 (40)	17 (56)	12 (40)	0	0

Mounting Height (ft)	Side-to-Side Distance			
	0.5fc/5lx m (ft)	1fc/11lx m (ft)	2fc/22lx m (ft)	5fc/54lx m (ft)
6 (20)	23 (76)	18 (60)	13 (44)	6 (20)
9 (30)	26 (84)	18 (60)	14 (45)	0
12 (40)	27 (88)	20 (64)	7 (24)	0

NEMA 7x7, Clear Glass, 5000K CCT
 REPORT NUMBER: AMLZL8CG6BUM
 Luminaire Lumens 18,104

POLAR CANDELA DISTRIBUTION

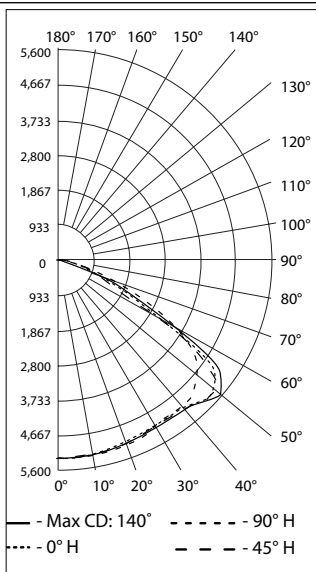

ISOFOOT CANDLE PLOT AT 45°

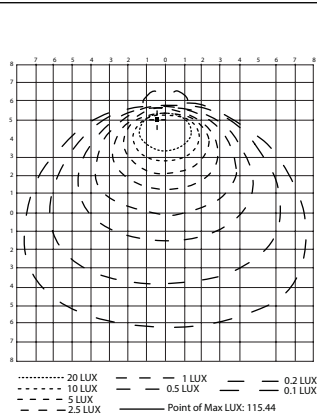

FLOOD SUMMARY

	Efficiency	Lumens	Horizontal Spread	Vertical Spread
Field (10%)	98.3%	17,835	132°	145°
Beam (50%)	90%	16,330	93°	121°
Total	100%	18,104		

Tilt Angle– 45 Degree LLF–0.9

Mounting Height (ft)	Forward Throw Distance			
	0.5fc/5lx m (ft)	1fc/11lx m (ft)	2fc/22lx m (ft)	5fc/54lx m (ft)
6 (20)	16 (52)	12 (40)	9 (30)	5 (18)
9 (30)	9 (30)	13 (42)	9 (30)	0
12 (40)	18 (60)	12 (40)	0	0

Mounting Height (ft)	Side-to-Side Distance			
	0.5fc/5lx m (ft)	1fc/11lx m (ft)	2fc/22lx m (ft)	5fc/54lx m (ft)
6 (20)	27 (88)	22 (72)	15 (50)	10 (32)
9 (30)	31 (102)	22 (72)	16 (54)	2 (6)
12 (40)	32 (104)	24 (80)	12 (40)	0

Areamaster™ Generation 2 LED Zone 1 Luminaire

Floodlight for Hazardous Locations

ATEX/IECEX:
 Zone 1, 2, 21 and 22
 Ex eb mb op is IIC
 II 2 GD
 IP64, 66, 67

ATEX/IECEX:
 IK08

Photometric Data – DATA SHOWN IS ABSOLUTE

NEMA 7x6, Clear Glass, 5000K
 REPORT NUMBER: AMLZL8CG7BUM
 Luminaire Lumens 18,558

POLAR CANDELA DISTRIBUTION

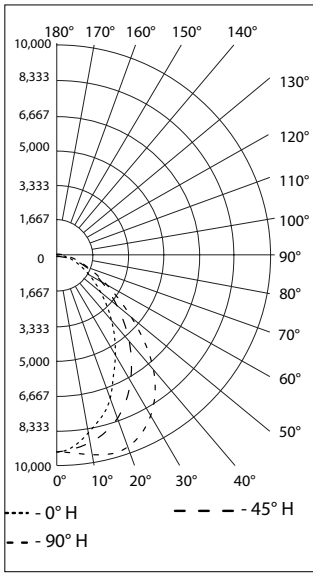

ISOFOOT CANDLE PLOT AT 45°

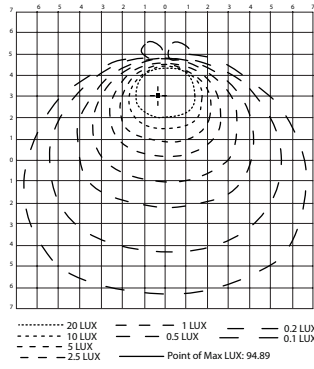

FLOOD SUMMARY

	Efficiency	Lumens	Horizontal Spread	Vertical Spread
Field (10%)	96%	17,846	138°	127°
Beam (50%)	65.1%	12,103	94°	69°
Total	100%	18,558		

Tilt Angle– 45 Degree LLF–0.9

Mounting Height (ft)	Forward Throw Distance			
	0.5fc/5lx m (ft)	1fc/11lx m (ft)	2fc/22lx m (ft)	5fc/54lx m (ft)
6 (20)	17 (56)	13 (44)	11 (36)	7 (24)
9 (30)	19 (63)	16 (53)	12 (41)	4 (12)
12 (40)	20 (66)	18 (60)	12 (40)	0

Mounting Height (ft)	Side-to-Side Distance			
	0.5fc/5lx m (ft)	1fc/11lx m (ft)	2fc/22lx m (ft)	5fc/54lx m (ft)
6 (20)	24 (80)	18 (60)	16 (52)	11 (36)
9 (30)	29 (96)	23 (75)	18 (60)	4 (12)
12 (40)	32 (104)	24 (80)	12 (40)	0

APPLETON™

LED/FLOODLIGHTS: NEC/CEC, ATEX/IECEX ENCLOSED AND GASKETED

Areamaster™ Generation 2 HL Zone 1 LED Luminaire

Floodlight for Hazardous Locations

ATEX/IECEX:
 Zone 1, 2, 21 and 22
 Ex eb mb op is IIC
 II 2 GD
 IP66
 IK08

Applications

- For use in locations where:
 - Hazardous areas designated as: Zone 1, 2, 21 and 22
 - A high degree of corrosion resistance is required
 - Protection against gas, dust, water and moisture is necessary
- Typical applications include:
 - A wide range of harsh and hazardous areas where flammable gases and vapors are present, for example:
 - Oil and Gas Refineries
 - Petrochemical Plants
 - Foundries
 - Drilling Rigs
 - Pulp and Paper Mills
 - Food and Beverage Processing Facilities
 - Loading Docks
 - Power Plants
 - Water and Wastewater Treatment Facilities
 - Other areas where corrosive, wet, dirty and tough environments are a problem
 - IP64, 66, 67; marine and wet locations
 - Extreme hot/cold temperature environments: -40 °C to +55/65 °C (-40 °F to +131/149 °F)



Features

- Three lumen outputs provide up to 36,000 lumens.

Nominal Lumens ①	Wattage (W)	Efficacy (lpw)	HID Equivalent	Model Number
23,000	166	139	1000W	AMHZL1
28,500	206	138	1000W-1500W	AMHZL2
36,000	278	130	1500W	AMHZL3

① Nominal lumen value for 5000K CCT. Detailed lumen information provided in tables.

- Separate field wiring compartment with screw terminal block for easy and secure connection (can accept UL/CSA 26-10 AWG, and 0.12mm²-5.3mm²)
- Two 3/4" NPT entries provided. Metric M20 plugs available.
- Yoke bracket is designed to accommodate traditional Areamaster brackets and slipfitters for easy retrofit.
- Choice of color temperature (CCT): 5000K cool white, 4000K neutral white or 3000K warm white
- Rugged and compact housing with superior thermal design translates to long luminaire life
- Heavy duty, high temperature silicone rubber gaskets
- Thermal shock and impact resistant clear or frosted glass lens
- Standard 6Kv surge protection
- Captive fasteners secure on piece lens
- Field replaceable LED driver and lens cover
- Photobiological safety rating: Risk Group Zero (RG0) with frosted glass; Risk Group One (RG1) with clear glass

Options

- Improved safety cable design with multiple retention points, purchase separately.
- Guard and visor available, purchase separately
- Slip-fitters and mounting brackets available for easy pole or wall mounting

Standard Materials

- Housing and lens door: copperfree aluminum (4/10 of 1% maximum)
- Gaskets: silicone rubber
- Yoke: zinc plated HR steel
- Bolts: stainless steel
- Close up plugs: (1) aluminum provided
- Guard and safety cable: stainless steel
- Visor: aluminum

Standard Finishes

- Housing, lens cover, visor and yoke mount: architectural bronze polyester

ATEX/IECEX Certifications and Compliances

- Certification Type: Areamaster Gen 2
 - Gas: Zone 1 and 2
 - Conforming to ATEX 2014/34/EU: II 2G
 - Type of Protection: Ex eb mb op is IIC Gb
 - Temperature Class: T6 to T4
 - Dust: Zones 21 and 22
 - Conforming to ATEX 2014/34/EU: II 2D
 - Type of Protection: Ex tb IIIC Db, Ex op is IIIC Db
 - Surface Temperature: +85°C to +100°C (-185°F to +212°F)
- Ambient Temperature: -40 °C to +65 °C (-40 °F to +149 °F)
- ATEX Certificate: ITS18ATEX303521
- IECEX Certificate: IECEx ITS 18.0031
- Index of Protection according to EN/IEC 60529: IP64, 66, 67
- Impact Resistance (shock): IK08
- Photobiological Safety, IEC 62778 and IEC 62471: RG0 with frosted glass, RG1 with clear glass

Areamaster™ Generation 2 HL Zone 1 LED Luminaire Floodlight for Hazardous Locations

ATEX/IECEX:
Zone 1, 2, 21 and 22
Ex eb mb op is IIC
II 2 GD
IP66
IK08

Order using catalog numbering guides below or select catalog number from tables on following pages.

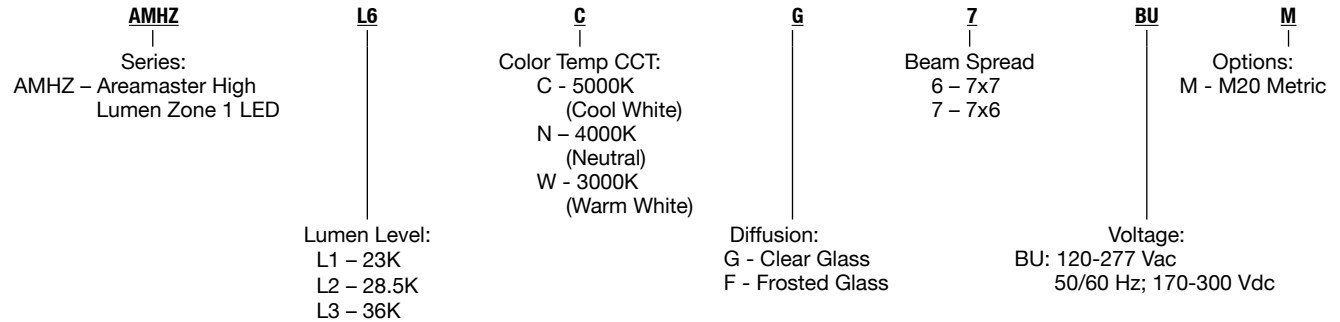

Lumen Output Tables:

Lumen Output for Clear Glass Lens			
Luminaire Beam Spread	AMHZL1	AMHZL2	AMHZL3
NEMA 7x6, 5000K CCT, CRI 70	23,146	28,307	35,946
NEMA 7x6, 3000K CCT, CRI 80	21,211	25,940	32,941
NEMA 7x7, 5000K CCT, CRI 70	22,556	27,588	35,171
NEMA 7x7, 3000K CCT, CRI 70	20,670	25,281	32,231

Lumen Output for Frosted Glass Lens			
Luminaire Beam Spread	AMHZL1	AMHZL2	AMHZL3
NEMA 7x7, 5000K CCT, CRI 70	18,746	22,859	29,171
NEMA 7x7, 3000K CCT, CRI 80	17,179	20,948	26,733

① Frosted Glass is only available with NEMA 7x7 light pattern
② All lumen values are typical (tolerance +/- 10%)



Areamaster™ Generation 2 HL Zone 1 LED Luminaire

Floodlight for Hazardous Locations

ATEX/IECEX:
 Zone 1, 2, 21 and 22
 Ex eb mb op is IIC
 II 2 GD
 IP66
 IK08

Electrical Ratings

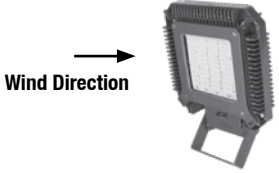
Voltage Suffix	Voltage (V)	Input Power (Watts)	Input Current (Amps)	Power Factor (PF)	Total Harmonic Distortion (THD)	Model Number
BU	120 Vac	165	1.4	0.99	< 20%	AMHZL1
	277 Vac	161	0.6	0.93		
	170 Vdc	162	1	N/A		
	300 Vdc	162	0.6	N/A		
	120 Vac	205	1.7	0.99	< 20%	AMHZL2
	277 Vac	195	0.8	0.94		
	170 Vdc	202	1.2	N/A		
	300 Vdc	202	0.7	N/A		
	120 Vac	275	2.4	0.99	< 20%	AMHZL3
	277 Vac	265	1	0.94		
	170 Vdc	270	1.7	N/A		
	300 Vdc	265	0.9	N/A		

Luminaire Category	Image	Frontal Projected Area (FPA) mm (ft²)	Drag Coefficient (DC)	Effective Projected Area (EPA) = FPA*DC mm (ft²)
90° to Ground-Worst Case Mounting		0.6 (2.04)	1.20	0.75 (2.45)
45° to Ground-Standard Mounting		0.4 (1.44)	1.20	0.5 (1.73)

APPLETON™

LED/FLOODLIGHTS: NEC/CEC, ATEX/IECEX ENCLOSED AND GASKETED

Areamaster™ Generation 2 HL Zone 1 LED Luminaire

Floodlight for Hazardous Locations

ATEX/IECEX:
 Zone 1, 2, 21 and 22
 Ex eb mb op is IIC
 II 2 GD
 IP66
 IK08

ATEX/IECEX Temperature Codes

Gas			Dust			Model Number
T Rating			Surface T°			
Ta= +40 °C (+104 °F)	Ta= +55 °C (+131 °F)	Ta= +65 °C (+149 °F)	Ta= +40 °C (+104 °F)	Ta= +55 °C (+131 °F)	Ta= +65 °C (+149 °F)	
T5	T4	T4	85 °C (-185°F)	100 °C (212°F)	100 °C (212°F)	AMHZL1
T4	T4	T4	85 °C (-185°F)	100 °C (212°F)	100 °C (212°F)	AMHZL2
T4	T4	--	100 °C (212°F)	100 °C (212°F)	--	AMHZL3

“T” Numbers Represent the Maximum Internal Temperature or Maximum Surface Temperature

“T” #	T1	T2	ATEX/IECEX T3	T4	T5	T6
Temp. Range °C (°F)	301-450 (547-842)	201-300 (394-572)	136-200 (277-392)	101-135 (214-275)	86-100 (187-212)	85 (185)



APPLETON™

LED/FLOODLIGHTS: NEC/CEC, ATEX/IECEX ENCLOSED AND GASKETED

Areamaster™ Generation 2 HL Zone 1 LED Luminaire

Floodlight for Hazardous Locations

ATEX/IECEX:
 Zone 1, 2, 21 and 22
 Ex eb mb op is IIC
 II 2 GD
 IP66
 IK08

	Color Temperature (CCT)	Lumen Output	Wattage	Efficacy (lm/W)	Input Current (Amps)	Optical Pattern	Catalog Number
Frosted Glass — 120-277 Vac/170-300 Vdc							
	5000K	18,746	166	113	0.53	7x7 (159°x157°)	AMHZL1CF6BUM
	3000K	17,179		104			AMHZL1WF6BUM
	5000K	22,859	206	111	0.68	7x7 (159°x157°)	AMHZL2CF6BUM
	3000K	20,948		102			AMHZL2WF6BUM
	5000K	29,171	278	105	0.915	7x7 (159°x157°)	AMHZL3CF6BUM
	3000K	26,733		96			AMHZL3WF6BUM
Clear Glass — 120-277 Vac/170-300 Vdc							
	5000K	22,556	166	136	0.53	7x7 (137°x142°)	AMHZL1CG6BUM
	5000K	23,146		140		7x6 (137°x126°)	AMHZL1CG7BUM
	3000K	20,670		125		7x7 (137°x142°)	AMHZL1WG6BUM
	3000K	21,211		128		7x6 (137°x126°)	AMHZL1WG7BUM
	5000K	27,588	206	134	0.68	7x7 (137°x142°)	AMHZL2CG6BUM
	5000K	28,307		138		7x6 (138°x126°)	AMHZL2CG7BUM
	3000K	25,281		123		7x7 (137°x142°)	AMHZL2WG6BUM
	3000K	25,940		126		7x6 (138°x126°)	AMHZL2WG7BUM
	5000K	35,171	278	127	0.915	7x7 (137°x142°)	AMHZL3CG6BUM
	5000K	35,946		130		7x6 (137°x126°)	AMHZL3CG7BUM
	3000K	32,231		116		7x7 (137°x142°)	AMHZL3WG6BUM
	3000K	32,941		119		7x6 (137°x126°)	AMHZL3WG7BUM

APPLETON™

LED/FLOODLIGHTS: NEC/CEC, ATEX/IECEX ENCLOSED AND GASKETED

Areamaster™ Generation 2 HL Zone 1 LED Luminaire Floodlight for Hazardous Locations

ATEX/IECEX:
Zone 1, 2, 21 and 22
Ex eb mb op is IIC
II 2 GD
IP66
IK08

Accessories and Replacement Parts





	Description	Catalog Number
Crossarm Mounting Bracket		
	Has 180° horizontal adjustment — degree marked. Facilitates mounting floodlight to crossarm or other flat surface, or to G-AM-8-WB. Includes floodlight yoke bolts. Malleable iron, zinc plated, chromate sealed, architectural bronze polyester finish.	G-AM-8-CA
Pipe or Wall Mount Bracket		
	Used with G-AM-8-CA. Clamps to 1" to 2-1/2" pipe, vertical or horizontal, or mounts on flat surfaces. Includes U-bolt and crossarm bracket bolts. Malleable iron, zinc plated, chromate sealed, with architectural bronze polyester finish.	G-AM-8-WB
		
Crossarm Mounting Bracket (G-AM-8-CA) used with Pipe or Wall Mount Bracket (G-AM-8-WB).		
Poletop Slip-Fitter		
	Slip-fits 1-1/2" or 2" pipe size poletop tenons. Includes floodlight yoke bolts, 3 locking bolts, and cord grip. Body is malleable iron-zinc plated, chromate sealed, with cast aluminum cap. Assembly has architectural bronze polyester finish.	G-SF20
	Slip-fits 1" or 1-1/2" pipe size poletop tenons. Includes floodlight yoke bolts, 3 locking bolts, and cord grip. Body is malleable iron-zinc plated, chromate sealed, with cast aluminum cap. Assembly has architectural bronze polyester finish.	AMLEDSF1
Poletop Slip-Fitter		
	Slip-fits 2" or 2-1/2" poletop tenons. Includes floodlight yoke bolts, 3 locking bolts, and cord grip. Malleable iron, zinc plated, chromate sealed, with architectural bronze polyester finish.	G-AM-8-SF

Areamaster™ Generation 2 HL Zone 1 LED Luminaire

Floodlight for Hazardous Locations

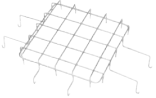
ATEX/IECEX:
 Zone 1, 2, 21 and 22
 Ex eb mb op is IIC
 II 2 GD
 IP66
 IK08

Accessories and Replacement Parts

	Description	Catalog Number
Wall Mount Bracket		
	Used with G-AM-8-SF and GSF-20 to provide a wall mounting option. Galvanized Steel.	GPSWB6
Wire Guard		
	Stainless steel.	LHGUARD
Safety Cable		
	Stainless steel.	LEDSC
Visor		
	Steel with architectural bronze polyester finish. For Dark Sky Friendly design.	AMLHV
Portable Floodlight Base		
	Portable floodlight base for temporary lighting applications. To be used with wire guard. Malleable iron with architectural bronze polyester finish.	G-AM-PFB
Replacement Covers		
		AMHZCLEAR
		AMHZFROST

APPLETON™

LED/FLOODLIGHTS: NEC/CEC, ATEX/IECEX ENCLOSED AND GASKETED

Areamaster™ Generation 2 HL Zone 1 LED Luminaire

Floodlight for Hazardous Locations

ATEX/IECEX:
 Zone 1, 2, 21 and 22
 Ex eb mb op is IIC
 II 2 GD
 IP66
 IK08

Replacement Drivers

	Voltage	Driver Wattage	Constant Current Setting	Luminaire Models	CCT	Catalog Number
	BU	100	530ma	AMHZL1	5000K	APMZ100C090UD53
					4000K	
					3000K	
	BU	150	680ma	AMHZL2	5000K	APMZ150C135UD68
					4000K	
					3000K	
	BU	150	930ma	AMHZL3	5000K	APMZ150C135UD93
					4000K	
					3000K	

Areamaster Generation 2 Accessory Weights

Description	Weight in kg (lbs)
AMHZL1, AMHZL2, AMHZL3 Luminaires	16.5 (36.5)
Yoke Bracket	1.41 (3.1)
Visor	0.2 (0.4)
Guard	0.2 (0.4)
Safety Cable	0.2 (0.4)
Crossarm Mounting Bracket G-AM-8-CA	1.4 (3.1)
Pipe or Wall Mount Bracket G-AM-8-WB	2.9 (6.4)
Poletop Slip-Fitter GSF20	1.4 (3.1)
Poletop Slip-Fitter AMLEDSF1	2.4 (5.3)
Poletop Slip-Fitter GAM8SF	—

APPLETON™

LED/FLOODLIGHTS: NEC/CEC, ATEX/IECEX ENCLOSED AND GASKETED

Areamaster™ Generation 2 HL Zone 1 LED Luminaire Floodlight for Hazardous Locations

ATEX/IECEX:
Zone 1, 2, 21 and 22
Ex eb mb op is IIC
II 2 GD
IP66
IK08

Dimensions in Millimeters (Inches)

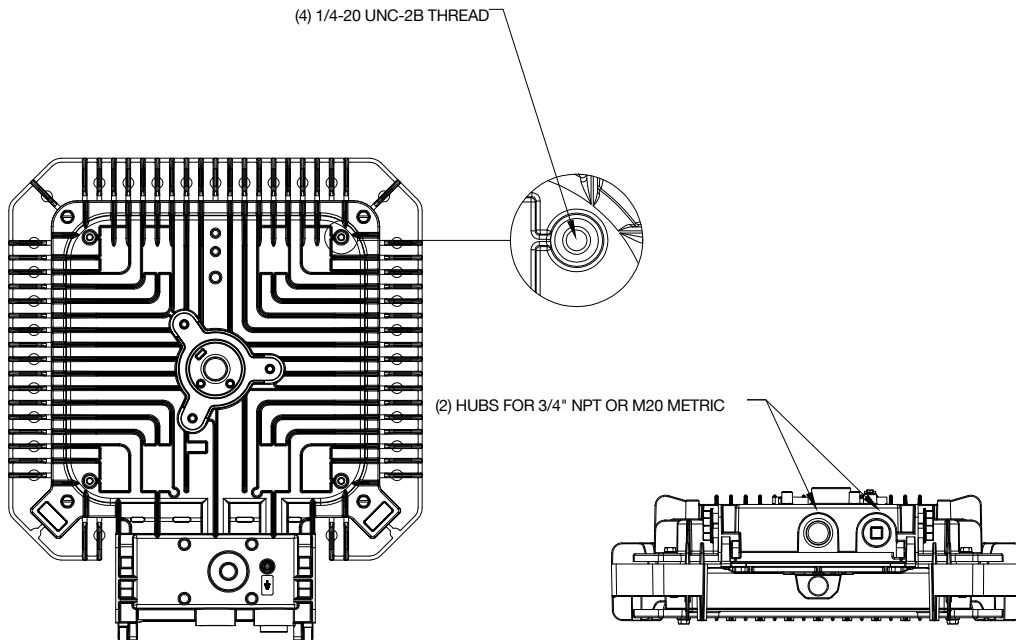
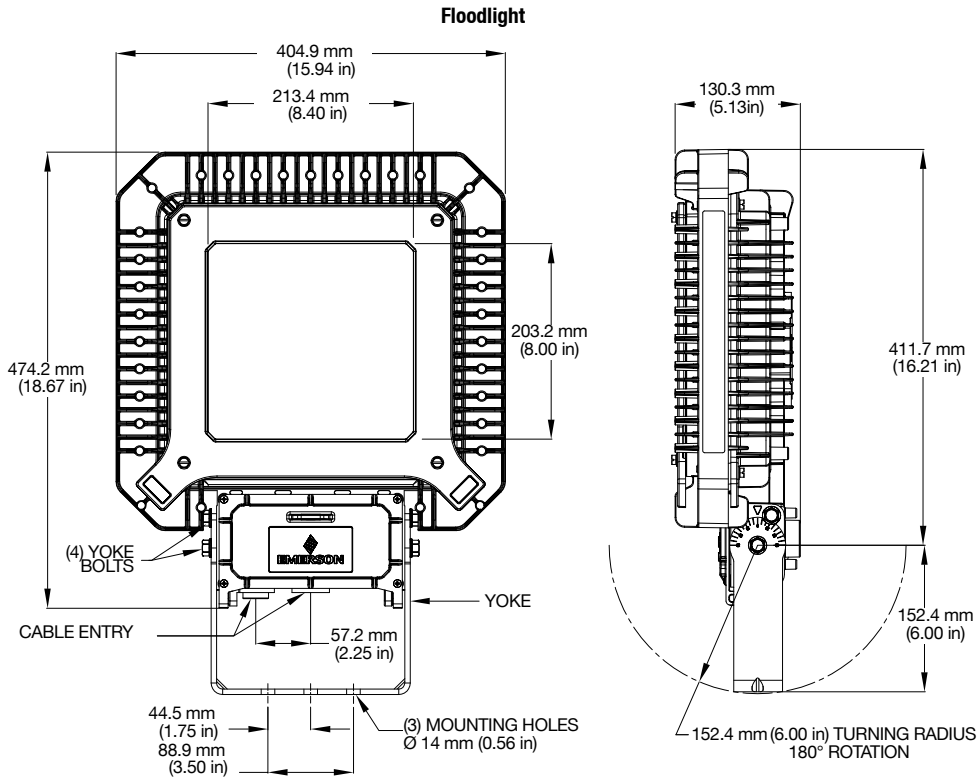

APPLETON™

LED/FLOODLIGHTS: NEC/CEC, ATEX/IECEX ENCLOSED AND GASKETED

Areamaster™ Generation 2 HL Zone 1 LED Luminaire Floodlight for Hazardous Locations

ATEX/IECEX:
Zone 1, 2, 21 and 22
Ex eb mb op is IIC
II 2 GD
IP66
IK08

Photometric Data — DATA SHOWN IS ABSOLUTE

NEMA 7x7, Frosted Glass, 5000K CCT

REPORT NUMBER: AMHZL1CF6BUM

Luminaire Lumens 18,746

POLAR CANDELA DISTRIBUTION

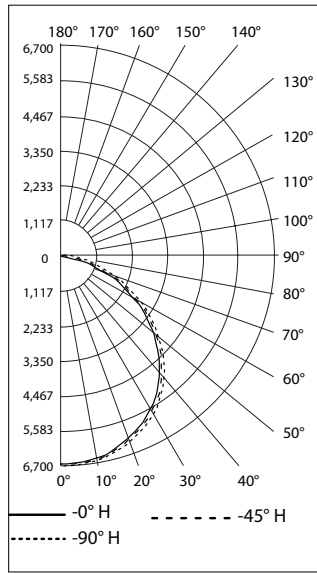

ISOFOOT CANDLE PLOT AT 45°

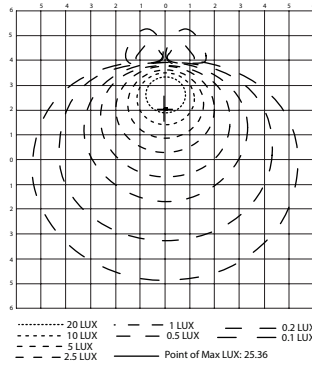

FLOOD SUMMARY

	Efficiency	Lumens	Horizontal Spread	Vertical Spread
Field (10%)	97.3%	18,288	159°	157°
Beam (50%)	74.4%	13,978	112°	111°
Total	100%	18,746		

Tilt Angle— 45 Degree LLF-0.9

Mounting Height m (ft)	Forward Throw Distance			
	0.5fc/5lx m (ft)	1fc/11lx m (ft)	2fc/22lx m (ft)	5fc/54lx m (ft)
12 (40)	20 (64)	15 (48)	20 (66)	0
15 (50)	18 (60)	14 (45)	0	0
18 (60)	20 (66)	10 (33)	0	0

Side-to-Side Distance

Mounting Height m (ft)	Side-to-Side Distance			
	0.5fc/5lx m (ft)	1fc/11lx m (ft)	2fc/22lx m (ft)	5fc/54lx m (ft)
12 (40)	29 (96)	22 (72)	12 (40)	0
15 (50)	30 (100)	18 (60)	0	0
18 (60)	29 (96)	15 (48)	0	0

NEMA 7x7, Clear Glass, 5000K

REPORT NUMBER: AMHZL1CG6BUM

Luminaire Lumens 22,556

POLAR CANDELA DISTRIBUTION

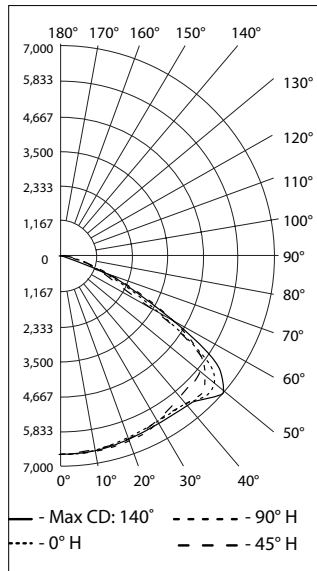

ISOFOOT CANDLE PLOT AT 45°

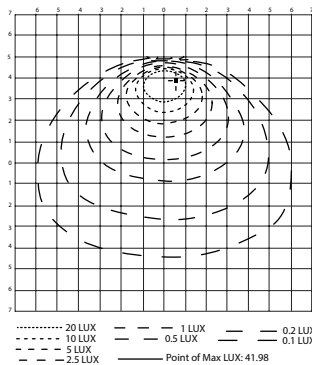

FLOOD SUMMARY

	Efficiency	Lumens	Horizontal Spread	Vertical Spread
Field (10%)	98.2%	22,194	137°	142°
Beam (50%)	89.3%	20,186	102°	116°
Total	100%	22,556		

Tilt Angle— 45 Degree LLF-0.9

Mounting Height m (ft)	Forward Throw Distance			
	0.5fc/5lx m (ft)	1fc/11lx m (ft)	2fc/22lx m (ft)	5fc/54lx m (ft)
12 (40)	24 (80)	18 (60)	13 (44)	0
15 (50)	24 (80)	18 (60)	11 (35)	0
18 (60)	27 (90)	18 (60)	0	0

Side-to-Side Distance

Mounting Height m (ft)	Side-to-Side Distance			
	0.5fc/5lx m (ft)	1fc/11lx m (ft)	2fc/22lx m (ft)	5fc/54lx m (ft)
12 (40)	37 (120)	27 (88)	20 (64)	0
15 (50)	35 (115)	26 (85)	12 (40)	0
18 (60)	37 (120)	26 (84)	0	0

Areamaster™ Generation 2 HL Zone 1 LED Luminaire

Floodlight for Hazardous Locations

ATEX/IECEX:
 Zone 1, 2, 21 and 22
 Ex eb mb op is IIC
 II 2 GD
 IP66
 IK08

Photometric Data – DATA SHOWN IS ABSOLUTE

NEMA 7x6, Clear Glass, 5000K
 REPORT NUMBER: AMHZL1CG7BUM
 Luminaire Lumens 23,146

POLAR CANDELA DISTRIBUTION

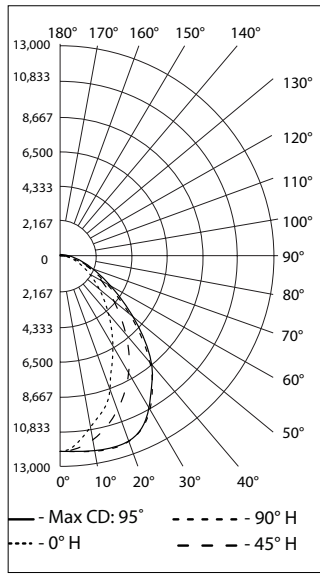

ISOFOOT CANDLE PLOT AT 45°

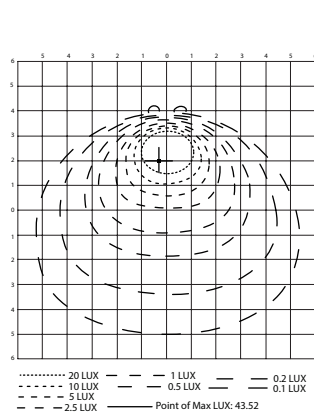

FLOOD SUMMARY

	Efficiency	Lumens	Horizontal Spread	Vertical Spread
Field (10%)	95.8%	22,227	137°	126°
Beam (50%)	66.4%	15,402	96°	68°
Total	100%	23,146		

Tilt Angle– 45 Degree LLF–0.9

Mounting Height m (ft)	Forward Throw Distance			
	0.5fc/5lx m (ft)	1fc/11lx m (ft)	2fc/22lx m (ft)	5fc/54lx m (ft)
12 (40)	24 (80)	18 (60)	13 (44)	0
15 (50)	24 (80)	18 (60)	11 (35)	0
18 (60)	27 (90)	18 (60)	0	0

Side-to-Side Distance

Mounting Height m (ft)	Side-to-Side Distance			
	0.5fc/5lx m (ft)	1fc/11lx m (ft)	2fc/22lx m (ft)	5fc/54lx m (ft)
12 (40)	32 (104)	27 (88)	20 (64)	0
15 (50)	34 (110)	27 (90)	15 (50)	0
18 (60)	37 (120)	26 (84)	0	0

NEMA 7x7, Frosted Glass, 5000K CCT

REPORT NUMBER: AMHZL2CF6BUM
 Luminaire Lumens 22,859

POLAR CANDELA DISTRIBUTION

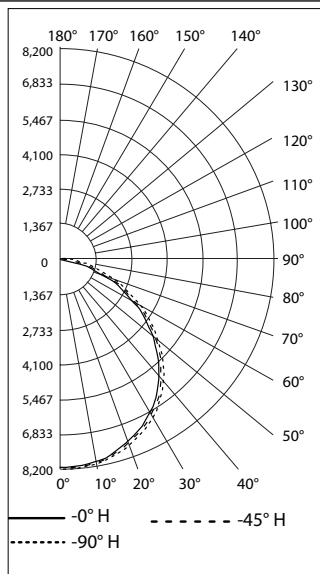

ISOFOOT CANDLE PLOT AT 45°

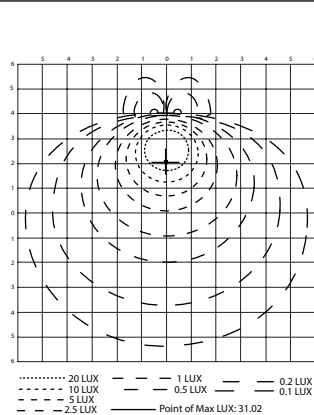

FLOOD SUMMARY

	Efficiency	Lumens	Horizontal Spread	Vertical Spread
Field (10%)	97.3%	22,299	159°	157°
Beam (50%)	74.5%	17,064	112°	111°
Total	100%	22,859		

Tilt Angle– 45 Degree LLF–0.9

Mounting Height m (ft)	Forward Throw Distance			
	0.5fc/5lx m (ft)	1fc/11lx m (ft)	2fc/22lx m (ft)	5fc/54lx m (ft)
12 (40)	22 (72)	15 (50)	10 (32)	0
15 (50)	21 (70)	15 (50)	6 (20)	0
18 (60)	22 (72)	15 (48)	0	0

Side-to-Side Distance

Mounting Height m (ft)	Side-to-Side Distance			
	0.5fc/5lx m (ft)	1fc/11lx m (ft)	2fc/22lx m (ft)	5fc/54lx m (ft)
12 (40)	29 (96)	24 (80)	12 (40)	0
15 (50)	34 (110)	23 (75)	9 (30)	0
18 (60)	33 (108)	18 (60)	0	0

APPLETON™

LED/FLOODLIGHTS: NEC/CEC, ATEX/IECEX ENCLOSED AND GASKETED

Areamaster™ Generation 2 HL Zone 1 LED Luminaire Floodlight for Hazardous Locations

ATEX/IECEX:
Zone 1, 2, 21 and 22
Ex eb mb op is IIC
II 2 GD
IP66
IK08

Photometric Data — DATA SHOWN IS ABSOLUTE
NEMA 7x7, Clear Glass, 5000K
REPORT NUMBER: AMHZL2CG6BUM
Luminaire Lumens 27,588

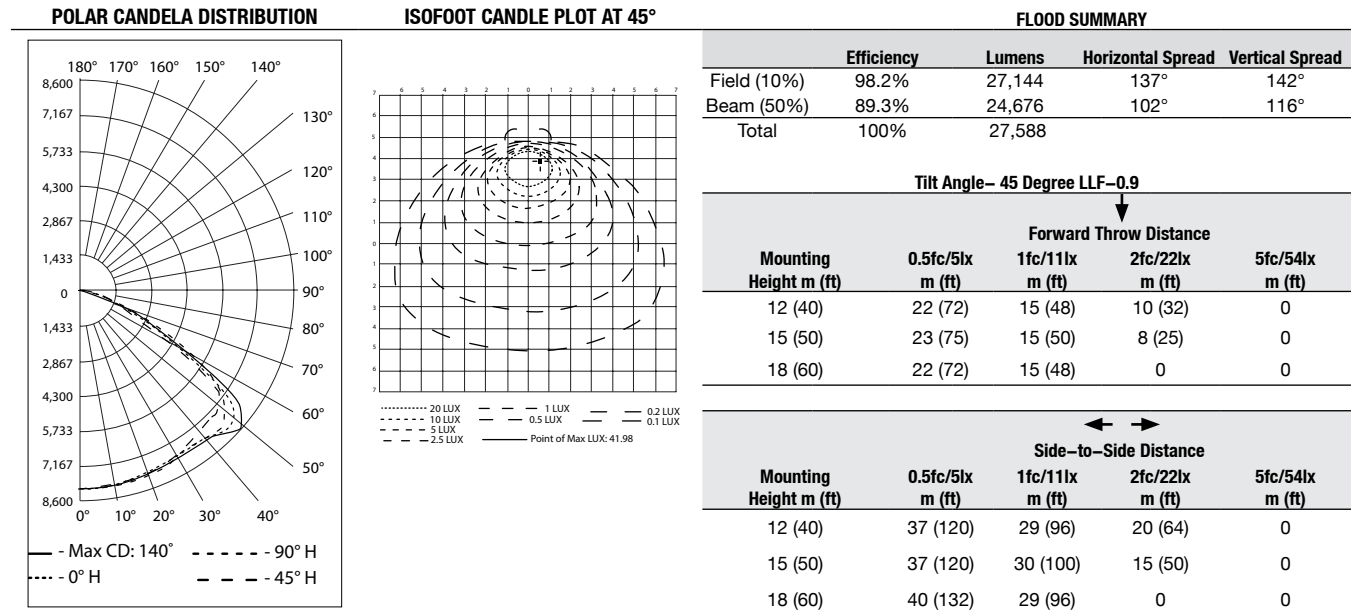

NEMA 7x6, Clear Glass, 5000K
REPORT NUMBER: AMHZL2CG7BUM
Luminaire Lumens 28,307

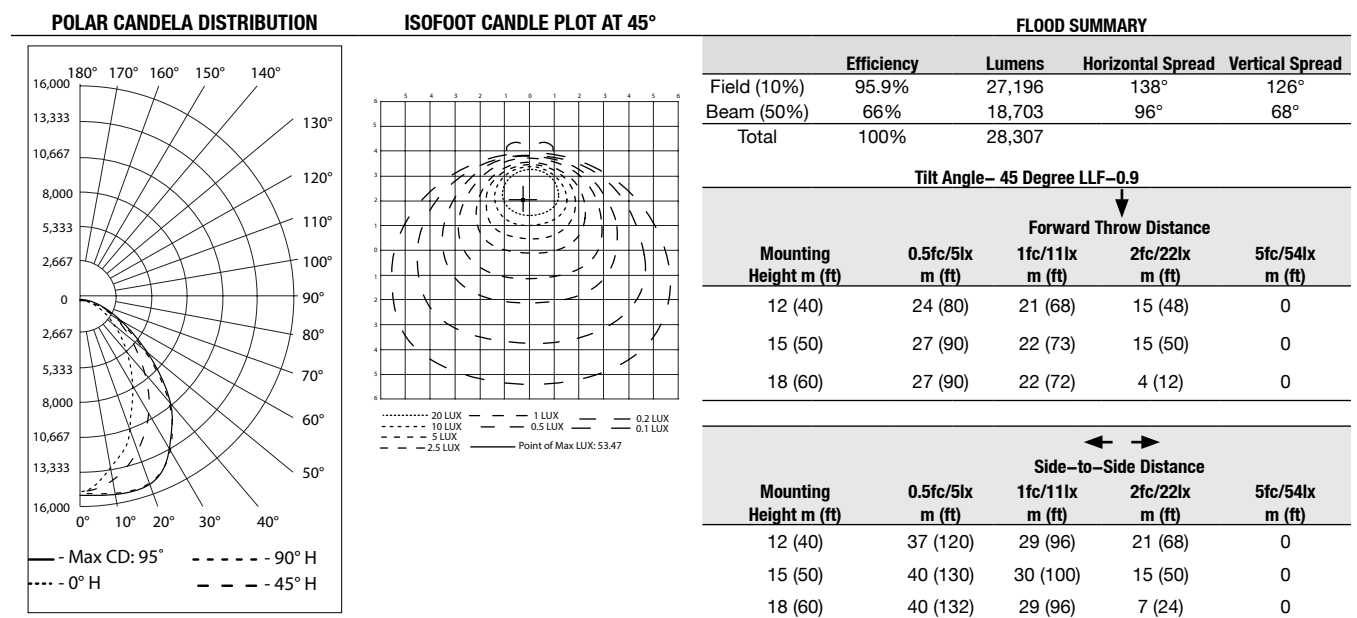

Areamaster™ Generation 2 HL Zone 1 LED Luminaire

Floodlight for Hazardous Locations

ATEX/IECEX:
 Zone 1, 2, 21 and 22
 Ex eb mb op is IIC
 II 2 GD
 IP66
 IK10

Photometric Data – DATA SHOWN IS ABSOLUTE
 NEMA 7x7, Frosted Glass, 5000K CCT
 REPORT NUMBER: AMHZL3CF6BUM
 Luminaire Lumens 29,171

POLAR CANDELA DISTRIBUTION

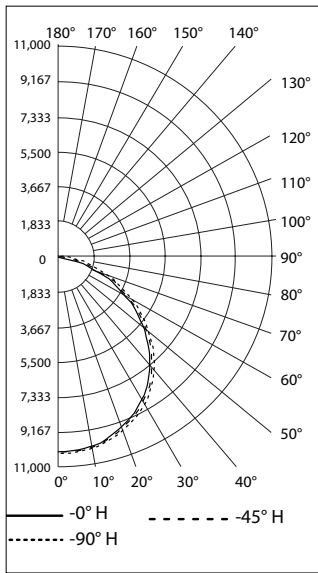

ISOFOOT CANDLE PLOT AT 45°

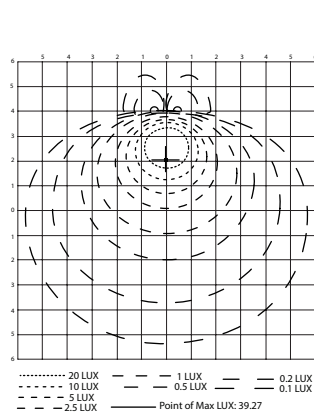

FLOOD SUMMARY

	Efficiency	Lumens	Horizontal Spread	Vertical Spread
Field (10%)	97.4%	28,461	159°	157°
Beam (50%)	74.6%	21,798	112°	111°
Total	100%	29,171		

Tilt Angle– 45 Degree LLF–0.9

Mounting Height m (ft)	Forward Throw Distance			
	0.5fc/5lx m (ft)	1fc/11lx m (ft)	2fc/22lx m (ft)	5fc/54lx m (ft)
12 (40)	24 (80)	18 (60)	12 (40)	0
15 (50)	24 (80)	18 (60)	9 (30)	0
18 (60)	26 (84)	18 (60)	4 (12)	0

Side-to-Side Distance

Mounting Height m (ft)	Side-to-Side Distance			
	0.5fc/5lx m (ft)	1fc/11lx m (ft)	2fc/22lx m (ft)	5fc/54lx m (ft)
12 (40)	37 (120)	24 (80)	20 (64)	0
15 (50)	37 (120)	24 (80)	15 (50)	0
18 (60)	37 (120)	22 (72)	4 (12)	0

NEMA 7x7, Clear Glass, 5000K
 REPORT NUMBER: AMHZL3CG6BUM
 Luminaire Lumens 35,171

POLAR CANDELA DISTRIBUTION

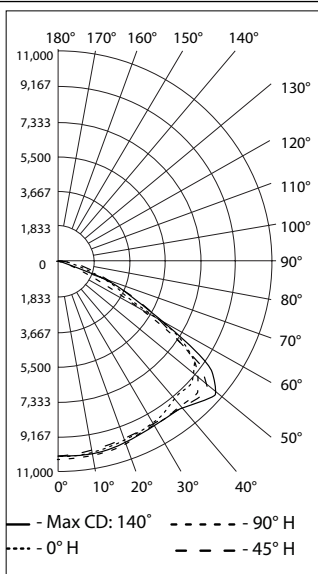

ISOFOOT CANDLE PLOT AT 45°

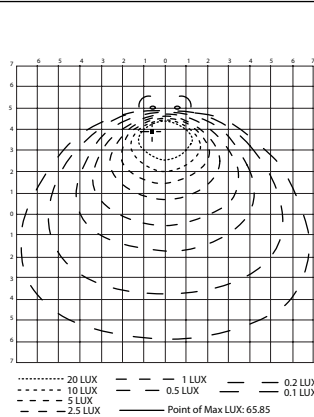

FLOOD SUMMARY

	Efficiency	Lumens	Horizontal Spread	Vertical Spread
Field (10%)	98.2%	34,615	137°	141°
Beam (50%)	88.5%	31,180	101°	115°
Total	100%	35,171		

Tilt Angle– 45 Degree LLF–0.9

Mounting Height m (ft)	Forward Throw Distance			
	0.5fc/5lx m (ft)	1fc/11lx m (ft)	2fc/22lx m (ft)	5fc/54lx m (ft)
12 (40)	24 (80)	18 (60)	12 (40)	2 (8)
15 (50)	23 (75)	18 (60)	9 (30)	0
18 (60)	24 (78)	18 (60)	7 (24)	0

Side-to-Side Distance

Mounting Height m (ft)	Side-to-Side Distance			
	0.5fc/5lx m (ft)	1fc/11lx m (ft)	2fc/22lx m (ft)	5fc/54lx m (ft)
12 (40)	44 (144)	32 (104)	24 (80)	0
15 (50)	46 (150)	34 (110)	24 (80)	0
18 (60)	46 (150)	33 (108)	16 (54)	0

Areamaster™ Generation 2 HL Zone 1 LED Luminaire Floodlight for Hazardous Locations

ATEX/IECEX:
Zone 1, 2, 21 and 22
Ex eb mb op is IIC
II 2 GD
IP66
IK10

Photometric Data — DATA SHOWN IS ABSOLUTE
NEMA 7x6, Clear Glass, 5000K
REPORT NUMBER: AMHZL3CG7BUM
Luminaire Lumens 35,946

POLAR CANDELA DISTRIBUTION

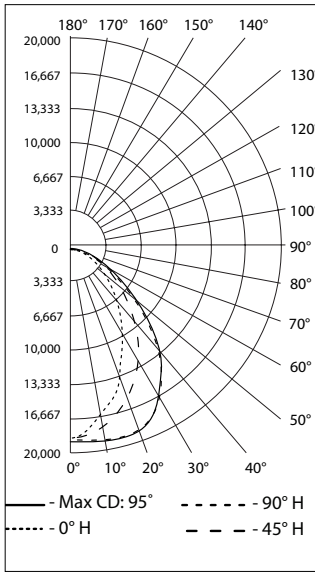

ISOFOOT CANDLE PLOT AT 45°

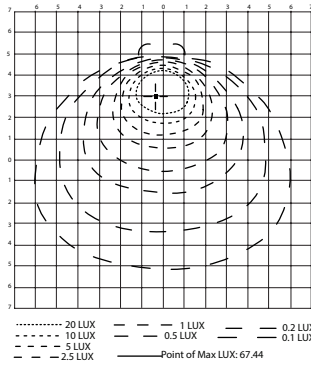

FLOOD SUMMARY

	Efficiency	Lumens	Horizontal Spread	Vertical Spread
Field (10%)	95.9%	34,526	137°	126°
Beam (50%)	65.3%	23,531	96°	67°
Total	100%	35,946		

Tilt Angle- 45 Degree LLF-0.9

Mounting Height m (ft)	Forward Throw Distance			
	0.5fc/5lx m (ft)	1fc/11lx m (ft)	2fc/22lx m (ft)	5fc/54lx m (ft)
12 (40)	27 (88)	23 (76)	18 (60)	7 (24)
15 (50)	30 (100)	23 (75)	17 (55)	0
18 (60)	31 (102)	24 (78)	15 (48)	0

Mounting Height m (ft)	Side-to-Side Distance			
	0.5fc/5lx m (ft)	1fc/11lx m (ft)	2fc/22lx m (ft)	5fc/54lx m (ft)
12 (40)	39 (128)	32 (104)	24 (80)	10 (32)
15 (50)	43 (140)	34 (110)	24 (80)	0
18 (60)	44 (144)	33 (108)	18 (60)	0

APPLETON™

LED/FLOODLIGHTS: NEC/CEC, ATEX/IECEX ENCLOSED AND GASKETED